

IP7 SERIES

IP/ETHERNET AUDIO SOLUTIONS

... clearly making waves

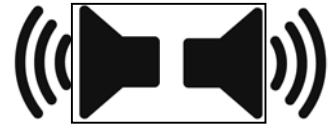

Dual Speaker Design
SPKR-11-BD-P

Flexible IP7 Series Products power the most demanding intercom and paging applications. Voice-quality audio is delivered over Ethernet/IP in local area (LAN) and wide area networks (WAN). The series' modular, IP edge-device design provides for superior scalability in applications of all sizes-- assuring success today and in the future.

IP SPEAKER SYSTEMS

- ☑ Integrated 8 Watt IP Audio Amplifier with Power over Ethernet (PoE)
- ☑ Connect VoIP Telephony Systems via TalkMaster™ SIP Media Gateway (SIP 2.0)
- ☑ Multicast Protocol enables seamless, clear, low bandwidth audio distribution
- ☑ Hardened surface-mount design for demanding indoor environments

Bi-Directional PoE-Enabled Hallway Speaker

The Digital Acoustics SPKR-11-BD-P Bi-Directional Speaker is a completely self-contained system with IP Amplifier and dual speaker cluster. The enclosure projects sound laterally (from the speaker ends) to maximize efficiency and the length of hallway covered.

Single CAT 5/6 cable installation from PoE Switch, no additional wiring is required. Quick installation to interior wall provides hallway paging of voice, tones and background music. The heavy-duty steel enclosure includes a white epoxy powder coating.

- High intelligibility from dual, 4-inch speakers
- Reduces installation labor and materials costs
- Single bi-directional speaker replaces multiple ceiling-mount speakers
- Designed for challenging environments: hallways with hard surface walls or ceilings
- Built-in IP Amplifier facilitates paging zone management
- Wall mounts with four #10 screws, toggle bolts recommended



Digital Acoustics, LLC

37 Sherwood Terrace, Unit 111
Lake Bluff, IL 60045

Toll-Free +1 877.724.3387
Direct +1 847.604.9256
FAX +1 847.604.9346



Dual Speaker Design
SPKR-11-BD-P

Applications

- Building, Campus and District-wide Paging
- Corporate Emergency Notification
- SIP 2.0 VoIP Phone Systems Integrated Paging
- Background Music

Vertical Markets

- Education
- Security
- Transportation
- Financial Services

Speaker

Speaker Type and Size 2, 4" Square 4 ohm Moisture Resistant
Speaker Power Rating 10 watts each
Magnet Type and Weight BeFe Ceramic 4.8 oz.
Sensitivity 92 dB SPL at 1 Watt 1 Meter
Maximum SPL 98 dB SPL at 8 Watts 1 Meter
Dispersion 130 degrees
Frequency Response 130 Hz - 9 kHz
Hallway length for optimum coverage 40 – 110 feet
Weight 5.5 pounds

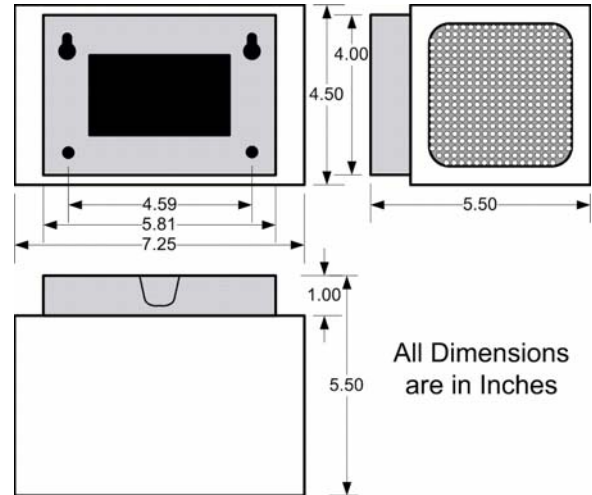

Ordering Information

Hardware
SPKR-11-BD-P IP-Enabled 4" (dual) Bi-Directional Speaker

Software
TM-LE Single Console Command Software (Included)
TM-EE Multi-Console Command Software
TM-SMG SIP Media Gateway (VoIP Access)

Integrated IP7-SS8

Network Protocols TCP, UDP, IP, ARP, ICMP, IGMP, MULTICAST
Network Interface 10/100 Base-T Ethernet, Auto-MDIX
Core Technology ICC-256 50 MIPS SoC (System On A Chip)
IP Address Assignment Static, DHCP
Transport Bandwidth Nominal 64kbps
Audio Protocol G.711. 8/16bit PCM/uLaw
Audio Latency <200ms Auto-Adaptive
Power (Nominal) PoE (15.4W)
PoE Standards 802.3af (15.4W)
Diagnostics LED Status, USB, Temperature and Power Monitoring
Remote Diagnostics Reporting over Ethernet
Remote Programming Flash programmable via Ethernet
Fault Management Advanced Fail-Forward™ fault detection
Connector I/O RJ45
Temperature -30~70 C (Operating), -40 C~85 C (Storage)



SOFTWARE APPLICATIONS

- ❑ **TalkMaster Enterprise Edition** - Multi-console command software for sophisticated installations with 1000's of IP audio end-points. Control and configure intercoms and IP paging amplifiers from central console. Multiple computer consoles can share and control grouped or individual intercoms and paging amplifiers.
- ❑ **TalkMaster™ SMG - SIP Media Gateway** integrates the TMEE Intercom and Paging System into any SIP Version 2.0 compliant VoIP telephony system.
 - Assign Intercom and Paging end-points to telephone extensions.
 - Create and manage paging groups.
 - Create out-dial extensions so intercoms can call mobile phones.

SOFTWARE DEVELOPMENT KITS

- ❑ **TMEE Hardware SDK** - For developing client-server or single console applications. The DLL controls the IP Socket connections, provides a "Call Back" mechanism to report events and delivers the raw audio stream allowing your application to playback or transfer it to another computer or device. No GUI elements are included.
- ❑ **TMEE Console SDK** - Used to create custom Console applications that integrate with TMEE Server. The DLL communicates through the TMEE server for all intercom communications. Each instance of a custom application requires a TMEE Console License. Allows you to leverage all the capabilities of the TMEE Server.

DIGITAL ACOUSTICS® PRODUCT FAMILY

Intercoms and I/O Expansion products



ICC™ based IP Paging and Intercom OEM products



Speaker solutions to fit your specific needs



Software Development Kits

Integrate intercom and paging solutions into your application.

TalkMaster Enterprise Edition

- TMEE Hardware DLL
- TMEE Console DLL